

# Model: D3DS-150 X

## Data

---

Type: Semi-hermetic piston compressors

Producer: Copeland

Series: DISCUS

## Model: D3DS-150 X

### Technical data

Cylinder count:	3
Displacement [m <sup>3</sup> /h]:	49,9
Weight [kg]:	178
Oil charge [dm <sup>3</sup> ]:	3,4
Max. operating current [A]:	29
Locked rotor current [A]:	129
Power supply [V/~/Hz]:	380-420V/3/50Hz

### Connections

	<u>milimeters</u>	<u>inches</u>
Suction line:		1 5/8"
Discharge line:		1 1/8"

# Model: D3DS-150 X

## Capacity

---

R22

### Cooling capacity [kW]

$t_c \setminus t_e$	-25	-20	-15	-10	-5	0	5	10
30	15.90	20.07	24.97	30.68	37.33	45.03	53.87	63.98
35	14.85	18.89	23.58	29.04	35.37	42.69	51.10	60.72
40	13.82	17.71	22.20	27.39	33.41	40.35	48.33	57.45
45	-	16.55	20.83	25.76	31.45	38.01	45.55	54.17
50	-	15.43	19.49	24.15	29.51	35.68	42.77	50.89
55	-	-	18.19	22.57	27.60	33.38	40.02	47.63
60	-	-	16.94	21.04	25.72	31.11	37.29	44.39

### Power input [kW]

$t_c \setminus t_e$	-25	-20	-15	-10	-5	0	5	10
30	6.68	7.25	7.74	8.13	8.39	8.49	8.40	8.09
35	7.00	7.66	8.26	8.78	9.18	9.44	9.53	9.42
40	7.31	8.06	8.76	9.40	9.94	10.36	10.62	10.70
45	-	8.44	9.25	10.00	10.67	11.24	11.67	11.93
50	-	8.82	9.72	10.58	11.38	12.09	12.68	13.12
55	-	-	10.18	11.15	12.07	12.92	13.66	14.28
60	-	-	10.65	11.71	12.75	13.73	14.62	15.40

# Model: D3DS-150 X

## Capacity

---

### Current [A]

<b>t<sub>c</sub> \ t<sub>e</sub></b>	<b>-25</b>	<b>-20</b>	<b>-15</b>	<b>-10</b>	<b>-5</b>	<b>0</b>	<b>5</b>	<b>10</b>
<b>30</b>	13.59	14.47	15.23	15.84	16.24	16.39	16.25	15.77
<b>35</b>	14.08	15.10	16.04	16.85	17.48	17.88	18.02	17.85
<b>40</b>	14.56	15.72	16.82	17.82	18.67	19.32	19.74	19.86
<b>45</b>	-	16.32	17.58	18.76	19.82	20.72	21.39	21.82
<b>50</b>	-	16.91	18.32	19.68	20.94	22.07	23.01	23.71
<b>55</b>	-	-	19.05	20.58	22.04	23.39	24.58	25.56
<b>60</b>	-	-	19.78	21.47	23.12	24.68	26.11	27.36

### Mass flow [kg/s]

<b>t<sub>c</sub> \ t<sub>e</sub></b>	<b>-25</b>	<b>-20</b>	<b>-15</b>	<b>-10</b>	<b>-5</b>	<b>0</b>	<b>5</b>	<b>10</b>
<b>30</b>	302.98	385.92	481.99	594.60	727.17	883.12	1 065.85	1 278.78
<b>35</b>	293.16	375.77	471.13	582.66	713.78	867.89	1 048.42	1 258.78
<b>40</b>	283.35	365.46	459.94	570.22	699.71	851.82	1 029.98	1 237.59
<b>45</b>	-	355.28	448.72	557.57	685.27	835.21	1 010.82	1 215.52
<b>50</b>	-	345.56	437.77	545.04	670.76	818.37	991.26	1 192.87
<b>55</b>	-	-	427.41	532.91	656.50	801.60	971.61	1 169.95
<b>60</b>	-	-	417.94	521.51	642.79	785.20	952.16	1 147.07

# Model: D3DS-150 X



## Capacity

### C.O.P. [W/W]

$t_c \setminus t_e$	-25	-20	-15	-10	-5	0	5	10
30	2.38	2.77	3.22	3.77	4.45	5.30	6.42	7.91
35	2.12	2.47	2.85	3.31	3.85	4.52	5.36	6.45
40	1.89	2.20	2.53	2.91	3.36	3.90	4.55	5.37
45	-	1.96	2.25	2.58	2.95	3.38	3.90	4.54
50	-	1.75	2.01	2.28	2.59	2.95	3.37	3.88
55	-	-	1.79	2.02	2.29	2.58	2.93	3.34
60	-	-	1.59	1.80	2.02	2.27	2.55	2.88

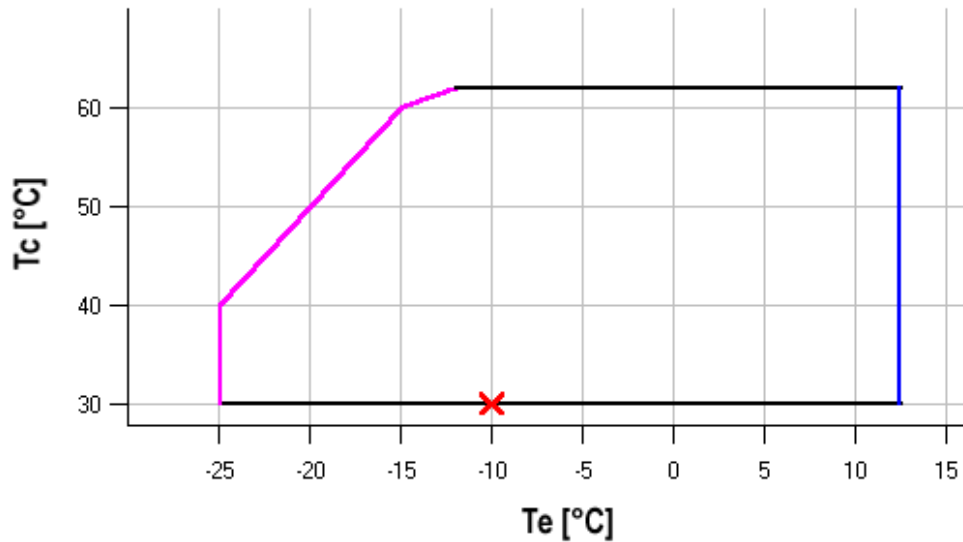
### Application range



 Maximum evaporating temperature  
 25°C suction gas return

Operating conditions: ISO; subcooling: 0 K, suction superheat: 10 K, return gas temperature: -

$t_c$  - Condensing temperature [°C]

$t_e$  - Evaporating temperature [°C]

# Model: D3DS-150 X

## Capacity

R134a

### Cooling capacity [kW]

<b>t<sub>c</sub> \ t<sub>e</sub></b>	<b>-20</b>	<b>-15</b>	<b>-10</b>	<b>-5</b>	<b>0</b>	<b>5</b>	<b>10</b>	<b>15</b>	<b>20</b>	<b>25</b>
<b>40</b>	9.57	12.61	16.24	20.56	25.68	31.70	38.73	46.87	-	-
<b>45</b>	8.61	11.54	15.01	19.12	23.99	29.72	36.40	44.15	53.06	63.25
<b>50</b>	7.69	10.49	13.79	17.69	22.30	27.71	34.04	41.39	49.85	59.54
<b>55</b>	6.81	9.48	12.60	16.27	20.60	25.70	31.66	38.59	46.60	55.78
<b>60</b>	-	8.50	11.42	14.86	18.91	23.67	29.25	35.76	43.29	51.96
<b>65</b>	-	7.55	10.27	13.46	17.21	21.63	26.82	32.89	39.94	48.08
<b>70</b>	-	-	9.14	12.07	15.51	19.58	24.37	29.99	36.55	44.15
<b>75</b>	-	-	-	10.69	13.82	17.51	21.90	27.06	33.11	40.16
<b>80</b>	-	-	-	9.33	12.12	15.44	19.40	24.10	29.64	36.12

### Power input [kW]

<b>t<sub>c</sub> \ t<sub>e</sub></b>	<b>-20</b>	<b>-15</b>	<b>-10</b>	<b>-5</b>	<b>0</b>	<b>5</b>	<b>10</b>	<b>15</b>	<b>20</b>	<b>25</b>
<b>40</b>	5.06	5.60	6.12	6.58	6.97	7.26	7.42	7.44	-	-
<b>45</b>	5.18	5.80	6.39	6.95	7.45	7.86	8.16	8.33	8.35	8.19
<b>50</b>	5.31	5.98	6.66	7.30	7.90	8.43	8.87	9.19	9.37	9.39
<b>55</b>	5.43	6.16	6.90	7.64	8.34	8.98	9.55	10.01	10.35	10.54
<b>60</b>	-	6.33	7.13	7.95	8.75	9.50	10.19	10.80	11.29	11.65
<b>65</b>	-	6.48	7.35	8.24	9.13	9.99	10.80	11.54	12.18	12.71
<b>70</b>	-	-	7.54	8.50	9.47	10.44	11.36	12.24	13.02	13.71
<b>75</b>	-	-	-	8.73	9.79	10.85	11.89	12.88	13.81	14.65
<b>80</b>	-	-	-	8.93	10.07	11.22	12.36	13.48	14.55	15.54

# Model: D3DS-150 X

## Capacity

### Current [A]

$t_c \setminus t_e$	-20	-15	-10	-5	0	5	10	15	20	25
<b>40</b>	11.96	12.63	13.28	13.88	14.38	14.76	14.96	14.95	-	-
<b>45</b>	12.16	12.89	13.63	14.35	15.00	15.55	15.96	16.18	16.18	15.92
<b>50</b>	12.35	13.13	13.96	14.80	15.60	16.33	16.94	17.40	17.66	17.70
<b>55</b>	12.51	13.36	14.28	15.23	16.18	17.09	17.90	18.60	19.13	19.46
<b>60</b>	-	13.56	14.57	15.64	16.74	17.82	18.85	19.78	20.58	21.20
<b>65</b>	-	13.73	14.83	16.03	17.27	18.53	19.77	20.94	22.00	22.92
<b>70</b>	-	-	15.07	16.38	17.78	19.22	20.66	22.07	23.40	24.61
<b>75</b>	-	-	-	16.71	18.26	19.88	21.53	23.17	24.77	26.28
<b>80</b>	-	-	-	17.01	18.70	20.50	22.36	24.25	26.11	27.92

### Mass flow [kg/s]

$t_c \setminus t_e$	-20	-15	-10	-5	0	5	10	15	20	25
<b>40</b>	248.46	322.62	407.34	504.49	615.94	743.57	889.26	1 054.87	-	-
<b>45</b>	237.60	312.14	397.11	494.36	605.79	733.25	878.63	1 043.81	1 230.65	1 441.03
<b>50</b>	226.84	301.53	386.50	483.63	594.79	721.85	866.69	1 031.19	1 217.22	1 426.65
<b>55</b>	216.35	290.94	375.68	472.44	583.09	709.52	853.58	1 017.16	1 202.14	1 410.38
<b>60</b>	-	280.53	364.80	460.95	570.86	696.40	839.45	1 001.88	1 185.57	1 392.38
<b>65</b>	-	270.45	354.00	449.31	558.24	682.66	824.46	985.49	1 167.65	1 372.81
<b>70</b>	-	-	343.45	437.67	545.38	668.44	808.74	968.15	1 148.55	1 351.80
<b>75</b>	-	-	-	426.18	532.43	653.90	792.47	950.01	1 128.40	1 329.51
<b>80</b>	-	-	-	414.99	519.54	639.18	775.78	931.22	1 107.36	1 306.09

# Model: D3DS-150 X

Capacity

## C.O.P. [W/W]

$t_c \setminus t_e$	-20	-15	-10	-5	0	5	10	15	20	25
40	1.89	2.25	2.65	3.12	3.68	4.37	5.22	6.30	-	-
45	1.66	1.99	2.35	2.75	3.22	3.78	4.46	5.30	6.36	7.73
50	1.45	1.75	2.07	2.42	2.82	3.29	3.84	4.50	5.32	6.34
55	1.25	1.54	1.82	2.13	2.47	2.86	3.32	3.85	4.50	5.29
60	-	1.34	1.60	1.87	2.16	2.49	2.87	3.31	3.83	4.46
65	-	1.17	1.40	1.63	1.89	2.17	2.48	2.85	3.28	3.78
70	-	-	1.21	1.42	1.64	1.88	2.14	2.45	2.81	3.22
75	-	-	-	1.22	1.41	1.61	1.84	2.10	2.40	2.74
80	-	-	-	1.04	1.20	1.38	1.57	1.79	2.04	2.32

## Application range

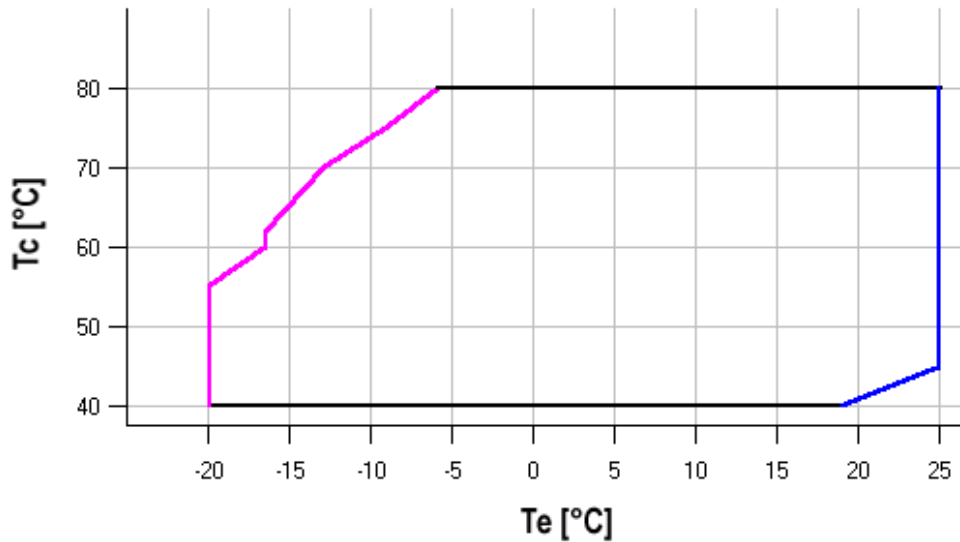

 Maximum evaporating temperature

 20K suction superheat

Operating conditions: ISO; subcooling: 0 K, suction superheat: 10 K, return gas temperature: -

$t_c$  - Condensing temperature [°C]

$t_e$  - Evaporating temperature [°C]

# Model: D3DS-150 X

## Capacity

R404A/R507

### Cooling capacity [kW]

<b>t<sub>c</sub> \ t<sub>e</sub></b>	<b>-40</b>	<b>-35</b>	<b>-30</b>	<b>-25</b>	<b>-20</b>	<b>-15</b>	<b>-10</b>	<b>-5</b>	<b>0</b>	<b>5</b>
<b>20</b>	9.92	12.84	16.42	20.71	25.82	31.81	38.76	46.76	55.89	66.22
<b>25</b>	9.45	12.29	15.72	19.81	24.65	30.31	36.87	44.42	53.03	62.78
<b>30</b>	8.74	11.48	14.75	18.61	23.16	28.47	34.62	41.69	49.76	58.91
<b>35</b>	7.89	10.50	13.58	17.19	21.43	26.36	32.08	38.65	46.16	54.69
<b>40</b>	6.97	9.44	12.30	15.64	19.54	24.08	29.34	35.39	42.33	50.21
<b>45</b>	-	8.37	11.01	14.06	17.60	21.72	26.50	32.01	38.34	45.56
<b>50</b>	-	7.40	9.78	12.51	15.68	19.36	23.64	28.59	34.29	40.83
<b>55</b>	-	-	8.71	11.11	13.88	17.10	20.85	25.21	30.27	36.09

### Power input [kW]

<b>t<sub>c</sub> \ t<sub>e</sub></b>	<b>-40</b>	<b>-35</b>	<b>-30</b>	<b>-25</b>	<b>-20</b>	<b>-15</b>	<b>-10</b>	<b>-5</b>	<b>0</b>	<b>5</b>
<b>20</b>	4.94	5.58	6.20	6.76	7.25	7.63	7.88	7.98	7.89	7.59
<b>25</b>	5.14	5.84	6.53	7.19	7.78	8.28	8.67	8.91	8.99	8.88
<b>30</b>	5.30	6.06	6.82	7.56	8.25	8.87	9.39	9.79	10.03	10.09
<b>35</b>	5.44	6.25	7.08	7.90	8.69	9.42	10.07	10.61	11.01	11.24
<b>40</b>	5.56	6.42	7.31	8.21	9.10	9.94	10.71	11.39	11.94	12.35
<b>45</b>	-	6.58	7.53	8.50	9.48	10.43	11.32	12.13	12.84	13.41
<b>50</b>	-	6.73	7.74	8.79	9.85	10.90	11.91	12.85	13.71	14.44
<b>55</b>	-	-	7.96	9.07	10.22	11.36	12.49	13.56	14.56	15.45



# Model: D3DS-150 X

## Capacity

### Current [A]

$t_c \setminus t_e$	-40	-35	-30	-25	-20	-15	-10	-5	0	5
<b>20</b>	11.80	12.62	13.41	14.13	14.73	15.19	15.45	15.47	15.21	14.63
<b>25</b>	12.03	12.92	13.81	14.67	15.46	16.12	16.62	16.91	16.96	16.71
<b>30</b>	12.23	13.18	14.18	15.17	16.12	16.98	17.71	18.27	18.62	18.71
<b>35</b>	12.41	13.42	14.51	15.63	16.73	17.79	18.74	19.56	20.20	20.61
<b>40</b>	12.57	13.64	14.81	16.05	17.31	18.54	19.72	20.79	21.71	22.44
<b>45</b>	-	13.85	15.10	16.45	17.85	19.27	20.65	21.96	23.16	24.20
<b>50</b>	-	14.07	15.39	16.84	18.38	19.96	21.55	23.10	24.57	25.91
<b>55</b>	-	-	15.68	17.22	18.89	20.64	22.42	24.20	25.93	27.57

### Mass flow [kg/s]

$t_c \setminus t_e$	-40	-35	-30	-25	-20	-15	-10	-5	0	5
<b>20</b>	213.46	283.76	365.22	461.38	575.78	711.97	873.49	1 063.88	1 286.68	1 545.43
<b>25</b>	213.82	284.60	366.32	462.50	576.71	712.47	873.33	1 062.82	1 284.50	1 541.91
<b>30</b>	208.60	279.22	360.55	456.12	569.48	704.16	863.71	1 051.68	1 271.59	1 527.00
<b>35</b>	199.77	269.59	349.89	444.20	556.06	689.02	846.62	1 032.40	1 249.91	1 502.67
<b>40</b>	189.30	257.68	336.30	428.70	538.43	669.02	824.03	1 006.98	1 221.43	1 470.91
<b>45</b>	-	245.45	321.75	411.60	518.54	646.13	797.89	977.37	1 188.12	1 433.67
<b>50</b>	-	234.88	308.21	394.86	498.38	622.31	770.18	945.55	1 151.95	1 392.92
<b>55</b>	-	-	297.66	380.47	479.91	599.53	742.88	913.48	1 114.89	1 350.64

# Model: D3DS-150 X



Capacity

## C.O.P. [W/W]

$t_c \setminus t_e$	-40	-35	-30	-25	-20	-15	-10	-5	0	5
20	2.01	2.30	2.65	3.06	3.56	4.17	4.92	5.86	7.08	8.72
25	1.84	2.10	2.41	2.76	3.17	3.66	4.25	4.98	5.90	7.07
30	1.65	1.90	2.16	2.46	2.81	3.21	3.68	4.26	4.96	5.84
35	1.45	1.68	1.92	2.18	2.47	2.80	3.18	3.64	4.19	4.86
40	1.25	1.47	1.68	1.91	2.15	2.42	2.74	3.11	3.54	4.07
45	-	1.27	1.46	1.65	1.86	2.08	2.34	2.64	2.99	3.40
50	-	1.10	1.26	1.42	1.59	1.78	1.99	2.22	2.50	2.83
55	-	-	1.09	1.22	1.36	1.50	1.67	1.86	2.08	2.34

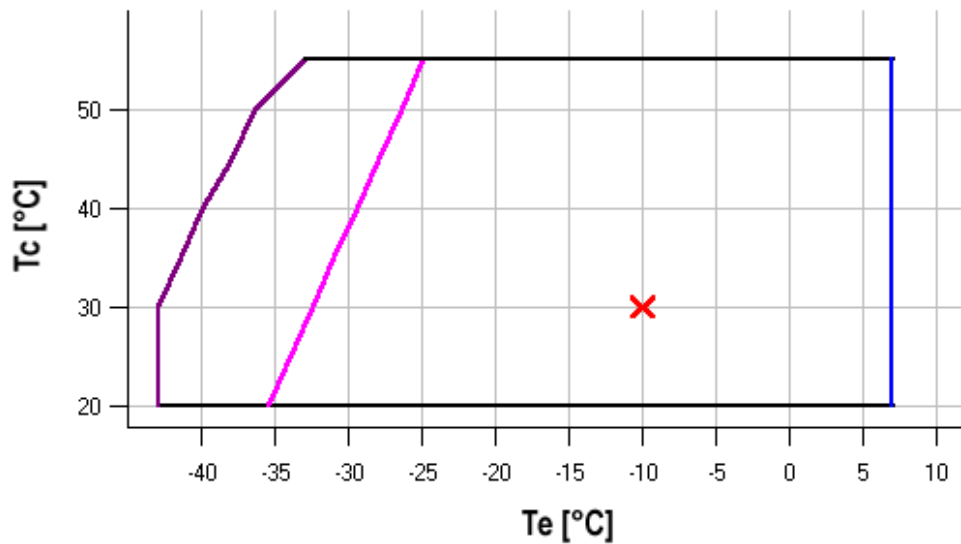
## Application range



-  Maximum evaporating temperature
-  25°C suction gas return
-  25°C suction gas return + additional cooling

Operating conditions: ISO; subcooling: 0 K, suction superheat: - K, return gas temperature: 20

$t_c$  - Condensing temperature [°C]

$t_e$  - Evaporating temperature [°C]

# Model: D3DS-150 X

## Capacity

---

R407C

### Cooling capacity [kW]

$t_c \setminus t_e$	-20	-15	-10	-5	0	5	10	15
35	16.89	21.27	26.65	33.09	40.65	49.42	59.46	-
40	15.74	19.80	24.79	30.78	37.84	46.03	55.42	-
45	14.64	18.39	23.01	28.55	35.10	42.72	51.48	-
50	-	17.03	21.27	26.39	32.44	39.50	47.63	-
55	-	15.70	19.58	24.28	29.84	36.34	43.86	-
60	-	-	17.93	22.21	27.29	33.25	40.16	-

### Power input [kW]

$t_c \setminus t_e$	-20	-15	-10	-5	0	5	10	15
35	7.01	7.62	8.19	8.70	9.08	9.28	9.27	-
40	7.40	8.08	8.76	9.39	9.92	10.31	10.51	-
45	7.79	8.53	9.30	10.05	10.73	11.29	11.69	-
50	-	8.97	9.82	10.68	11.49	12.22	12.81	-
55	-	9.40	10.32	11.28	12.22	13.11	13.88	-
60	-	-	10.81	11.86	12.92	13.95	14.90	-

# Model: D3DS-150 X

## Capacity

---

### Current [A]

$t_c \setminus t_e$	-20	-15	-10	-5	0	5	10	15
35	14.10	15.04	15.94	16.73	17.32	17.65	17.63	-
40	14.71	15.77	16.83	17.82	18.66	19.27	19.59	-
45	15.32	16.47	17.68	18.85	19.93	20.82	21.45	-
50	-	17.16	18.50	19.85	21.14	22.29	23.23	-
55	-	17.83	19.29	20.80	22.30	23.70	24.93	-
60	-	-	20.06	21.72	23.40	25.04	26.56	-

### Mass flow [kg/s]

$t_c \setminus t_e$	-20	-15	-10	-5	0	5	10	15
35	322.35	409.37	515.55	643.98	797.75	979.96	1 193.68	-
40	314.50	398.43	501.40	626.50	776.81	955.44	1 165.47	-
45	307.14	388.07	487.92	609.78	756.73	931.87	1 138.29	-
50	-	378.32	475.15	593.85	737.54	909.28	1 112.19	-
55	-	369.23	463.12	578.77	719.27	887.72	1 087.20	-
60	-	-	451.88	564.57	701.98	867.22	1 063.37	-

# Model: D3DS-150 X

## Capacity

### C.O.P. [W/W]

$t_c \setminus t_e$	-20	-15	-10	-5	0	5	10	15
35	2.41	2.79	3.25	3.80	4.48	5.32	6.41	-
40	2.13	2.45	2.83	3.28	3.81	4.46	5.27	-
45	1.88	2.16	2.47	2.84	3.27	3.78	4.40	-
50	-	1.90	2.17	2.47	2.82	3.23	3.72	-
55	-	1.67	1.90	2.15	2.44	2.77	3.16	-
60	-	-	1.66	1.87	2.11	2.38	2.70	-

### Application range

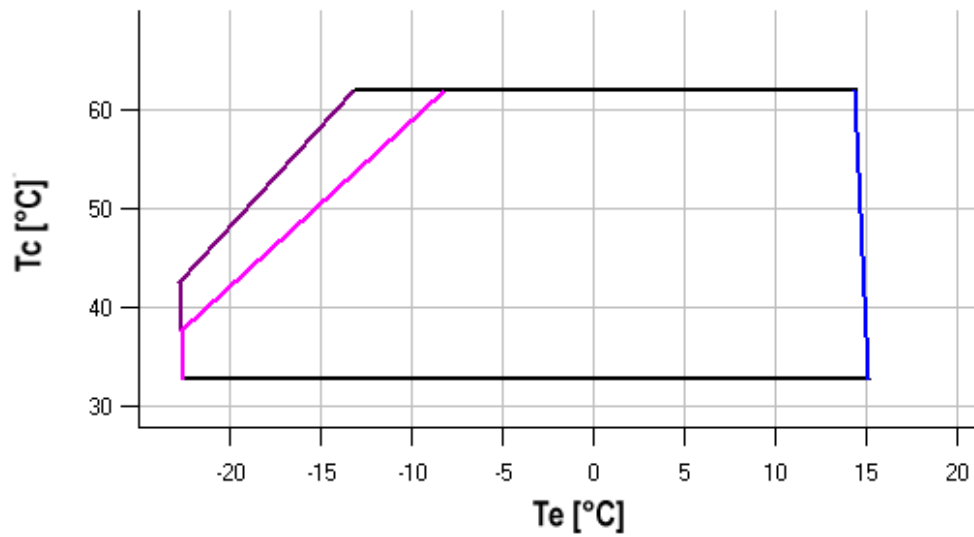

- Maximum evaporating temperature
- 25°C suction gas return
- 20K suction superheat

Operating conditions: ISO; subcooling: 0 K, suction superheat: 10 K, return gas temperature: -  
 $t_c$  - Condensing temperature [°C]  
 $t_e$  - Evaporating temperature [°C]

# Model: D3DS-150 X

## Dimensions

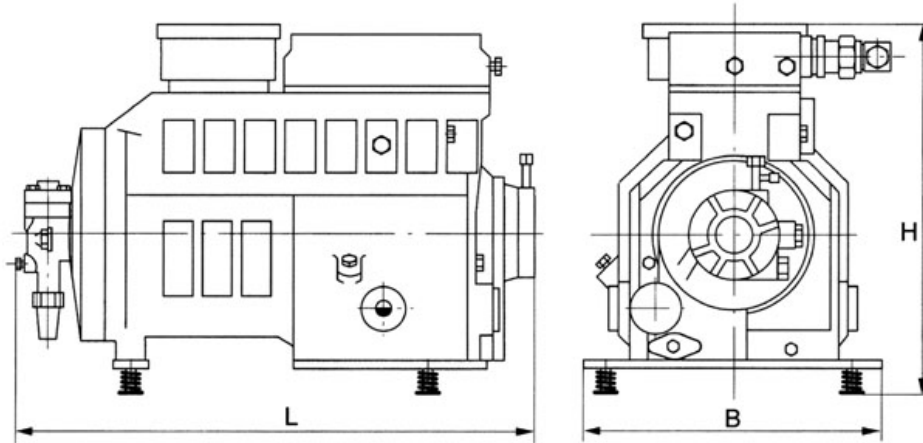

L	710 mm
B	370 mm
H	490 mm